

■ Installation

◇ Mounting examples

⚠ **DANGER! HIGH VOLTAGE! NEVER** touch the antenna while transmitting or tuning. Place the antenna in a position where you are sure it will not be touched.

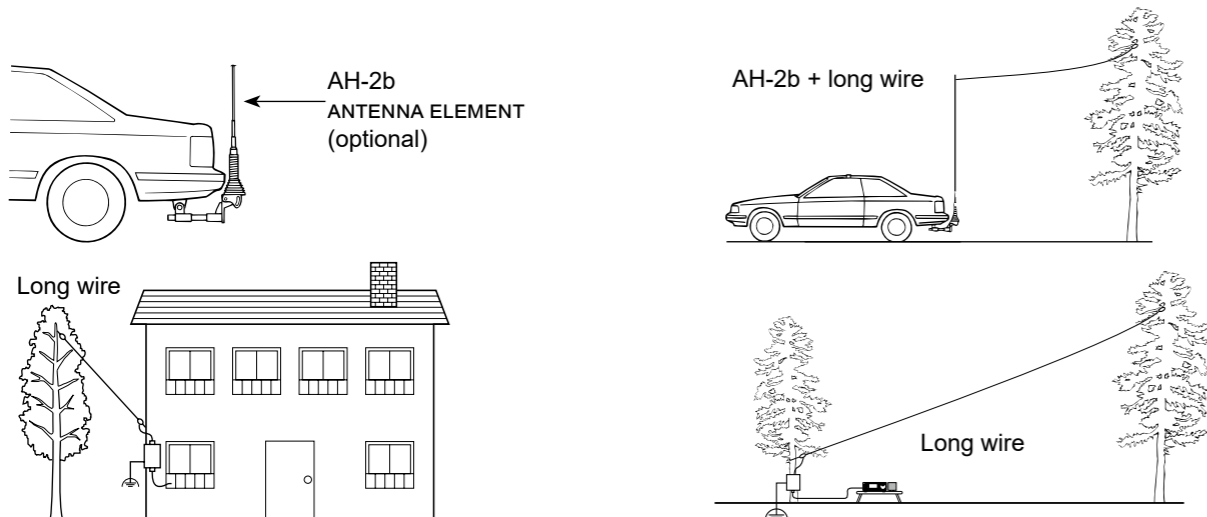

■ Operation

Tuning is required for each frequency. Be sure to retune the antenna before transmitting when you change the frequency— even slightly.

Example: IC-7300

- Turn ON the transceiver.
 - Each time you push **TUNER**, "TUNE" is displayed or goes out, and the AH-730 is turned ON or OFF (bypassed).
- Hold down **TUNER** for 1 second to start manual tuning.
 - The antenna tuner reduces the SWR to less than 2:1 after 2 ~ 3 seconds of tuning.
 - While tuning, "TUNE" blinks red.
 - If the antenna tuner cannot reduce the SWR to less than 2:1 after 15 seconds of tuning, "TUNE" goes out.

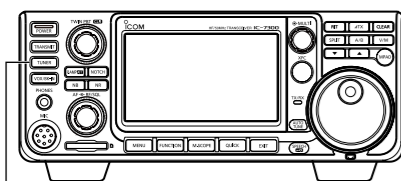

Hold down **TUNER** for 1 second.

- After tuning, "TUNE" is displayed.
 - When the long wire antenna cannot be tuned, "TUNE" goes out. In that case, the AH-730 is bypassed and the wire is directly connected.

NOTE: When the wire antenna cannot be tuned, confirm wire length and connection. Note that the AH-730 cannot tune a wire that is a $\frac{1}{2}\lambda$ long or on a multiple of that frequency.

Icom is not responsible for the destruction, damage to, or performance of any Icom or non-Icom equipment, if the malfunction is because of:

- Force majeure, including, but not limited to, fires, earthquakes, storms, floods, lightning, other natural disasters, disturbances, riots, war, or radioactive contamination.
- The use of Icom antenna tuners with any equipment that is not manufactured or approved by Icom.

Icom, Icom Inc. and the Icom logo are registered trademarks of Icom Incorporated (Japan) in Japan, the United States, the United Kingdom, Germany, France, Spain, Russia, Australia, New Zealand, and/or other countries.

■ Specifications

- Frequency range: 1.8 ~ 54 MHz (with an antenna longer than 7 m, 23 ft)
3.5 ~ 54 MHz (with the AH-2b)
- Maximum input power: 150 W
- Input impedance: 50 Ω
- Tuning power required: 5 ~ 15 watts
- Rated voltage: 13.8 V DC ±15% (current less than 0.7 A)
- Usable temperature range: -10°C ~ +60°C (+14°F ~ +140°F)
- VSWR: 2.0 : 1 or less (except antennas a one half wave or multiple of a one half wave in length)
- Weight (approximate): 2.5 kg (5.5 lb)
- Dimensions: 230 (W) × 80 (H) × 340 (D) mm, (projections not included) 9.1 (W) × 3.1 (H) × 13.4 (D) inches

Ⓛ All stated specifications are typical and subject to change without notice or obligation.

■ Options

- OPC-1465 SHIELDED CONTROL CABLE**
Cable length (approximate): 10 m, 32.8 ft
The same as supplied.
- AH-2b ANTENNA ELEMENT**
A 2.5 m long antenna element for mobile operation with AH-730.
Frequency coverage: 3.5 ~ 54 MHz with the AH-730.

Below statement is for UKCA purpose only
United Kingdom Authorised Importer: Icom (UK) Ltd.
Address: Blacksole House, Altira Park, Herne Bay, Kent, CT6 6GZ, U.K.

ICOM INSTRUCTIONS
AUTOMATIC ANTENNA TUNER
AH-730

Thank you for choosing this Icom product.
READ ALL INSTRUCTIONS carefully and completely before using this product.

■ Important

SAVE THESE INSTRUCTIONS— These instructions contain important operating instructions for the AH-730.

■ Features

- Wide tuning range**
The AH-730 provides reliable matching from 1.8 MHz to 54 MHz when using at least a 7 m (23 ft) antenna or 3.5 MHz to 54 MHz when using the AH-2b ANTENNA ELEMENT.
- Automatic digital control tuning**
The built-in 32 bit microprocessor chooses the lowest SWR using more than 1,040,000 different LC (coil/capacitor) combinations.
- 45 frequency memories for fast tuning**
The LC combinations of 45 previously-used frequencies are automatically memorized. Once a frequency is memorized, the AH-730 tunes on that frequency in less than 1 second. Note that the AH-730 does not memorize a frequency which is normally tuned within 2.5 seconds. Memories are retained only when the power is on.
- 0.3 W radiated power**
Radiated power during tuning is less than 0.3 W, minimizing interference to other stations.
- IPX4 weatherproof design**
The AH-730's tightly sealed plastic case allows convenient mounting virtually anywhere. The AH-730 can be mounted outdoors under your antenna.

NOTE: The AH-730 can be used with most of Icom HF transceiver, which covers HF through 50 MHz bands. However, the IC-706 and IC-736 can only be tuned in the 1.8 ~ 30 MHz range.

■ Supplied accessories

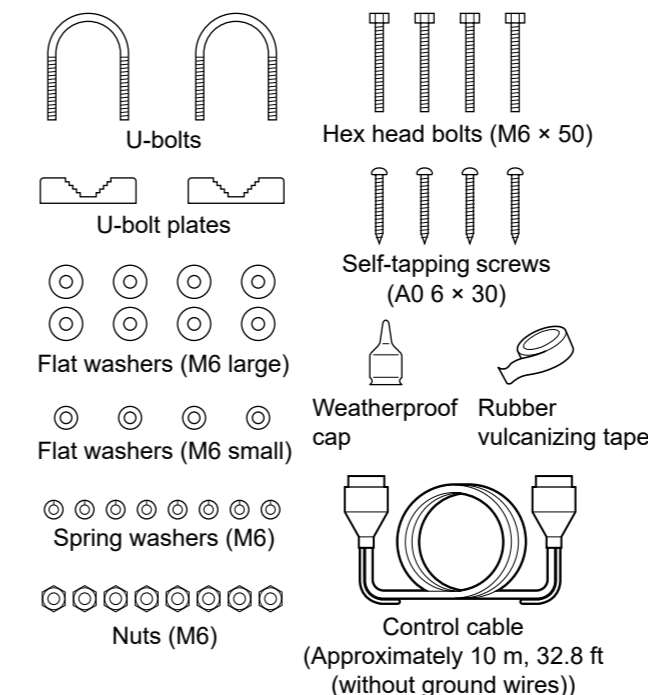

■ Explicit definitions

WORD	DEFINITION
⚠ DANGER!	Personal death, serious injury or an explosion may occur.
⚠ WARNING!	Personal injury, fire hazard or electric shock may occur.
CAUTION	Equipment damage may occur.
NOTE	If disregarded, inconvenience only. No risk of personal injury, fire or electric shock.

■ Precaution

- ⚠ **DANGER! NEVER** operate the antenna tuner without a solid ground. Always connect the ground wire to the ground terminal. **DO NOT** use the mounting plate as a ground terminal.
- ⚠ **DANGER! NEVER** transmit or tune without an antenna connected. Failure to use an antenna will damage the antenna tuner.
- ⚠ **DANGER! HIGH VOLTAGE! NEVER** touch the antenna while transmitting or tuning. Place the antenna in a position where you are sure it will not be touched.
- KEEP** the antenna tuner away from heavy rain and never immerse it in water. The antenna tuner meets IPX4 requirements for splash resistance. However, once the antenna tuner has been dropped, splash resistance cannot be guaranteed due to the fact that the antenna tuner may be cracked or the waterproof seal damaged, and so on.

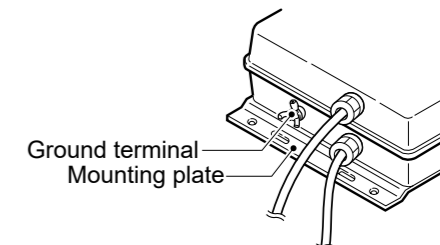

■ FCC information

This equipment has been tested and found to comply with the limits for a Class B digital device, pursuant to part 15 of the FCC Rules. These limits are designed to provide reasonable protection against harmful interference in a residential installation. This equipment generates, uses, and can radiate radio frequency energy and, if not installed and used in accordance with the instructions, may cause harmful interference to radio communications. However, there is no guarantee that interference will not occur in a particular installation. If this equipment does cause harmful interference to radio or television reception, which can be determined by turning the equipment off and on, the user is encouraged to try to correct the interference by one or more of the following measures:

- Reorient or relocate the receiving antenna.
- Increase the separation between the equipment and receiver.
- Connect the equipment into an outlet on a circuit different from that to which the receiver is connected.
- Consult the dealer or an experienced radio/TV technician for help.

CAUTION: Changes or modifications to this device, not expressly approved by Icom Inc., could void your authority to operate this device under FCC regulations.

This device complies with part 15 of the FCC Rules. Operation is subject to the following two conditions: (1) This device may not cause harmful interference, and (2) this device must accept any interference received, including interference that may cause undesired operation.

■ Disposal



The crossed-out wheeled-bin symbol on your product, literature, or packaging reminds you that in the European Union, all electrical and electronic products, batteries, and accumulators (rechargeable batteries) must be taken to designated collection locations at the end of their working life. Do not dispose of these products as unsorted municipal waste. Dispose of them according to the laws in your area.

■ Installation

CAUTION:

- NEVER modify, bend, twist, pull or heat the control cable and the coaxial cable.
- NEVER hang something heavy on the control cable and the coaxial cable.
- NEVER mount the AH-730 without securing the control cable and the coaxial cable so that they cannot be pulled or stretched.

◇ Waterproofing the antenna connection

CAUTION: If you skip the following steps, moisture will get into the connector, and this could damage the antenna tuner.

1. Cut off just the top of the weatherproof cap, and pass the antenna wire through the cap.

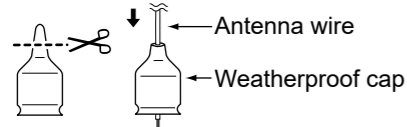

2. Insert the antenna wire into the opening of the crimp-on wire terminal.
 - ① Crimp or solder the antenna wire.

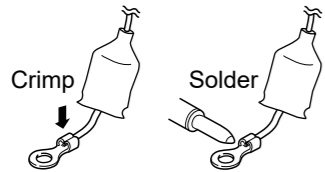

3. Put the crimp-on wire terminal, star washer, and wing nut on the base nut, in that order, and then tighten the wing nut.

- ① Make sure the base nut is tightened firmly before you tighten the wing nut, as shown below.
- ② Carefully bend the wire terminal up after you tighten the wing nut. (1)

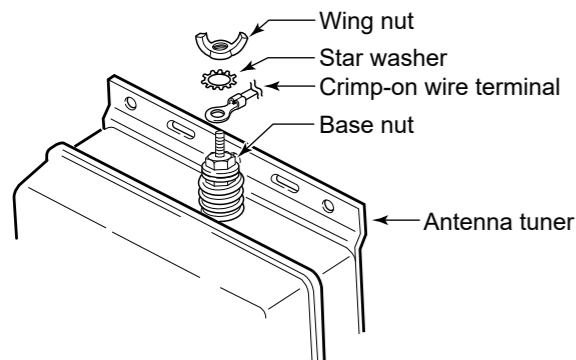

4. Place the weatherproof cap over as much of the insulator as possible. (2)
 - ① How far down it will go depends on the height of the wing nut.

■ About CE and DOC



Hereby, Icom Inc. declares that the versions of AH-730 which have the "CE" symbol on the product, comply with the essential requirements of the Radio Equipment Directive, 2014/53/EU, and the restriction of the use of certain hazardous substances in electrical and electronic equipment Directive, 2011/65/EU. The full text of the EU declaration of conformity is available at the following internet address: <https://www.icomjapan.com/support/>

5. Start wrapping the rubber vulcanizing tape at the bottom of the insulator, then the weatherproof cap, and finally the antenna wire to prevent water seeping. (3)
 - ① Wrap user supplied electrical tape over the rubber vulcanizing tape to secure waterproofing.

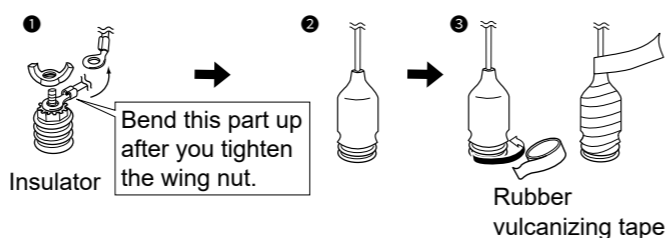

◇ Ground connections

The ground wire of the antenna tuner is used as an antenna element. The transceiver and antenna tuner must have an adequate ground connection. Otherwise, the overall efficiency of the transceiver and antenna tuner installation will be reduced. Interference, RF feedback, and electrical shocks from other equipment could also occur.

For best results, use the heaviest gauge wire or strap available, and make the connection as short as possible, as shown below.

- ① A long wire connected to the GND terminal as a counterpoise is also acceptable.

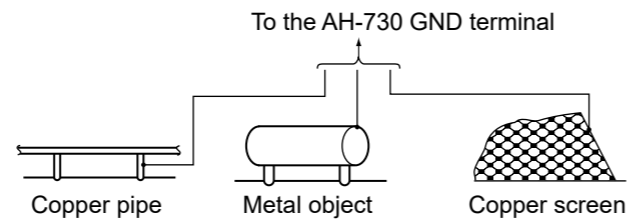

◇ Cable connections

NOTE: Connect a user supplied coaxial cable to the appropriate antenna connector if the transceiver has more than one. See your transceiver's instruction manual for details.

Example: IC-7300

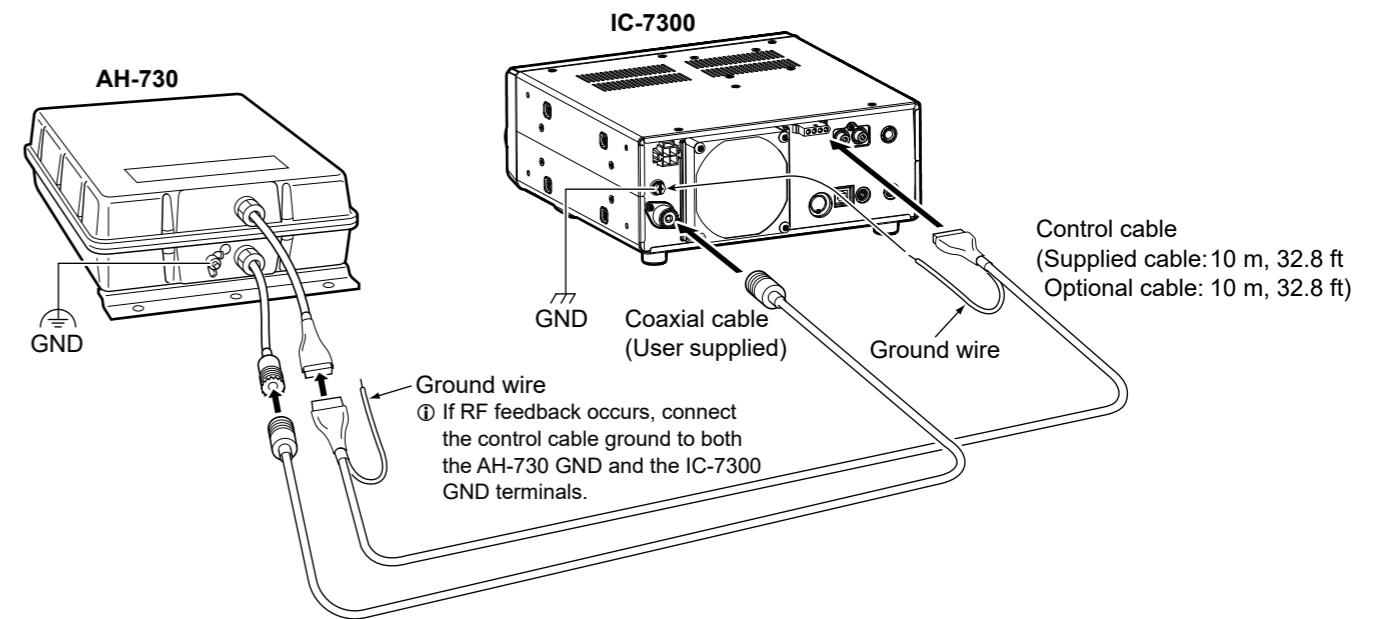

◇ Mounting the AH-730

CAUTION: Mount the AH-730 in a horizontal position or a vertical position with the antenna terminal up.

• Mounting on an antenna pole

Using the supplied U-bolts

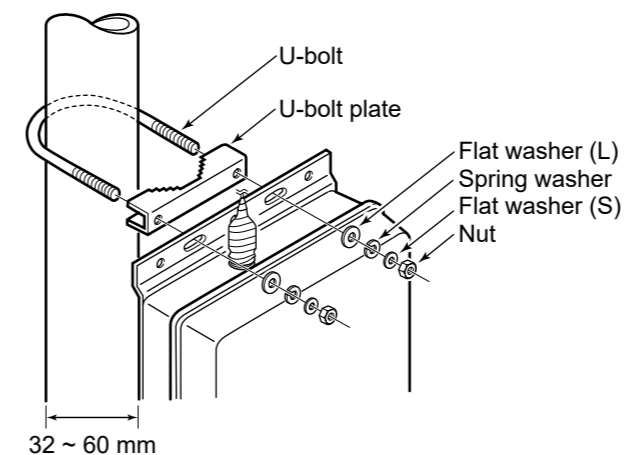

⚠ WARNING! Mount the AH-730 securely with the supplied nuts and bolts. Otherwise, vibrations and shocks could loosen the antenna tuner, making it fall, causing personal injury.

CAUTION: DO NOT mount the antenna tuner upside down.

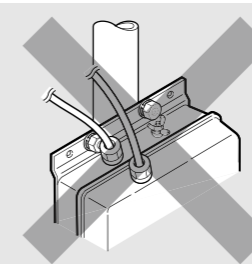

• Mounting on a flat location

Using nuts and bolts

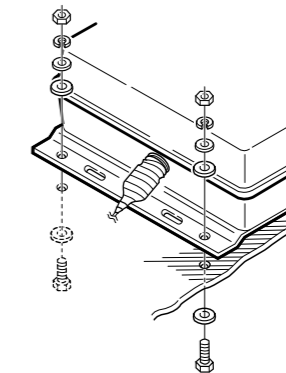

Using self-tapping screws

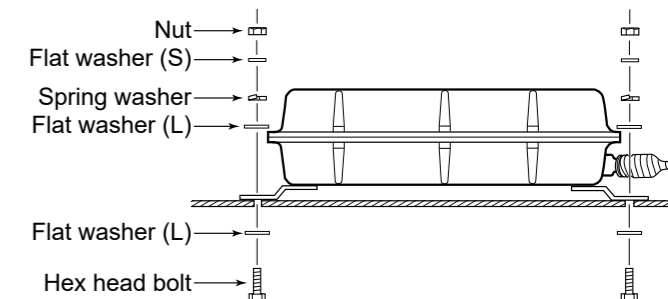
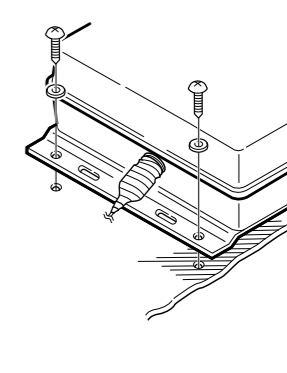

SINTONIZZATORE AUTOMATICO PER ANTENNA AH-730

Smaltimento



Il simbolo del cassonetto barrato riportato sul prodotto, sulle pubblicazioni o sull'imballaggio ricorda che nell'Unione Europea tutti i prodotti elettrici ed elettronici, le batterie e gli accumulatori (batterie ricaricabili) devono essere portati in punti raccolta stabiliti alla fine della durata in servizio. Non smaltire questi prodotti come rifiuti urbani indifferenziati. Smaltirli in base alle leggi vigenti nella propria area.

Informazioni su CE e sulla DDC



Il fabbricante, Icom Inc., dichiara che le versioni dell'AH-730 che hanno il simbolo "CE" sul prodotto sono conformi ai requisiti essenziali della Direttiva sulle apparecchiature radio, 2014/53/UE e alla limitazione dell'uso di determinate sostanze pericolose nella Direttiva sulle apparecchiature elettriche ed elettroniche, 2011/65/UE. Il testo completo della Dichiarazione di conformità UE è disponibile al seguente indirizzo Internet:
<https://www.icomjapan.com/support/>

Definizioni esplicite

PAROLA	DEFINIZIONE
⚠ PERICOLO!	Esiste la possibilità di morte, gravi lesioni personali o esplosione.
⚠ AVVERTENZA!	Rischio di lesioni personali, incendi o scosse elettriche.
ATTENZIONE	Rischio di danni all'apparecchiatura.
NOTA	Consigliata per un utilizzo ottimale. Non vi sono rischi di lesioni personali, incendi o scosse elettriche.

Icom non è responsabile per la distruzione, il danneggiamento o prestazioni di qualsiasi attrezzatura Icom o non se il malfunzionamento è causato da:

- Forza maggiore, che include, non limitandosi a, incendi, terremoti, tempeste, inondazioni, fulmini o altri disastri naturali, perturbazioni, rivolte, guerre o contaminazione radioattiva.
- L'utilizzo dei sintonizzatori per antenna Icom con qualsiasi apparecchiatura che non sia stata prodotta o approvata da Icom.

Icom, Icom Inc. e il logo Icom sono marchi registrati di Icom Incorporated (Giappone) in Giappone, Stati Uniti, Regno Unito, Germania, Francia, Spagna, Russia, Australia, Nuova Zelanda e/o in altri Paesi.

Grazie per aver scelto questo prodotto Icom.
LEGGERE TUTTE LE ISTRUZIONI attentamente e completamente prima di utilizzare questo prodotto.

Precauzioni

⚠ **PERICOLO! MAI** azionare il sintonizzatore per antenna senza una messa a terra solida. Collegare sempre il filo di terra al terminale di terra. **NON** utilizzare la piastra di montaggio come terminale di terra.

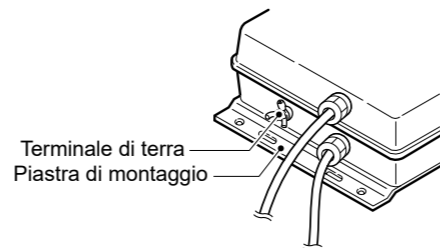

⚠ **PERICOLO! MAI** trasmettere o sintonizzare senza aver collegato un'antenna. Il mancato utilizzo di un'antenna danneggerà il sintonizzatore per antenna.

⚠ **PERICOLO! ALTO VOTAGGIO! MAI** toccare l'antenna durante la trasmissione o la sintonizzazione. Collocare l'antenna in una posizione in cui si è sicuri che non verrà toccata.

⚠ **AVVERTENZA!** Fissare saldamente l'AH-730 con i dadi e i bulloni in dotazione. In caso contrario, vibrazioni ed urti potrebbero allentare il sintonizzatore per antenna, provocandone la caduta con conseguenti lesioni personali.

ATTENZIONE: MAI modificare, piegare, torcere, tirare o riscaldare il cavo di controllo e il cavo coassiale.

ATTENZIONE: MAI appendere qualcosa di pesante al cavo di controllo e al cavo coassiale.

ATTENZIONE: MAI montare l'AH-730 senza fissare il cavo di controllo e il cavo coassiale in modo che non possano essere tirati o allungati.

ATTENZIONE: Montare l'AH-730 in posizione orizzontale o verticale con il terminale dell'antenna rivolto verso l'alto.

ATTENZIONE: NON montare il sintonizzatore per antenna capovolto.

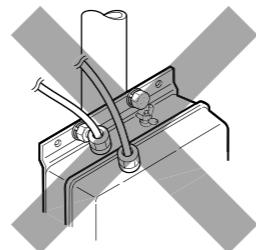

NOTA: Collegare un cavo coassiale fornito dall'utente al connettore dell'antenna appropriato se il ricetrasmittitore ne ha più di uno.

TENERE il sintonizzatore per antenna al riparo dalla forte pioggia e non immergerlo mai nell'acqua. Il sintonizzatore per antenna soddisfa i requisiti IPX4 per la resistenza agli schizzi. Tuttavia, in caso di caduta del sintonizzatore per antenna, la resistenza agli schizzi non può essere garantita a causa della rottura del sintonizzatore per antenna o di danni al sigillo impermeabile, ecc.

AUTOMATISCHER ANTENNENTUNER AH-730

Entsorgung



Das Symbol einer durchgestrichenen Abfalltonne auf Rädern auf dem Produkt, den zugehörigen Unterlagen oder der Verpackung weist darauf hin, dass in den Ländern der EU alle elektrischen und elektronischen Produkte, Batterien und Akkumulatoren (aufladbare Batterien) am Ende ihrer Lebensdauer bei einer benannten Sammelstelle abgegeben werden müssen. Entsorgen Sie diese Produkte nicht über den unsortierten Hausmüll. Entsorgen Sie sie entsprechend den bei Ihnen geltenden Bestimmungen.

Über CE und Konformitätserklärung



Hiermit erklärt Icom Inc., dass die Versionen des AH-730, die das „CE“-Symbol auf dem Produkt haben, den grundlegenden Anforderungen der Funkgeräte-Richtlinie 2014/53/EU und der Richtlinie zur Beschränkung der Verwendung bestimmter gefährlicher Stoffe in Elektro- und Elektronikgeräten, 2011/65/EU, entsprechen. Der vollständige Wortlaut der EU-Konformitätserklärung ist unter der folgenden Internetadresse verfügbar:
<https://www.icomjapan.com/support/>

Definitionen der Kennzeichnungen

WORT	DEFINITION
⚠ GEFAHR!	Lebensgefahr, Gefahr von schweren Verletzungen oder Explosionsgefahr.
⚠ WARNUNG!	Es besteht die Gefahr von Verletzungen, Bränden oder elektrischen Schlägen.
VORSICHT	Es besteht die Gefahr von Sachschäden.
HINWEIS	Empfehlung zur optimalen Nutzung. Es besteht keine Gefahr von Verletzungen, Bränden oder elektrischen Schlägen.

Icom ist nicht verantwortlich für die Zerstörung, Beschädigung oder Leistung eines Icom- oder Nicht-Icom-Geräts, wenn die Fehlfunktion folgende Ursachen hat:

- Höhere Gewalt, einschließlich, aber nicht beschränkt auf, Brände, Erdbeben, Stürme, Überschwemmungen, Blitzschlag, andere Naturkatastrophen, Unruhen, Krawalle, Krieg oder radioaktive Kontamination.
- Die Verwendung des Icom-Antennentuners mit jeglichen Geräten, die nicht von Icom hergestellt oder zugelassen sind.

Icom, Icom Inc. und das Icom-Logo sind eingetragene Warenzeichen von Icom Incorporated (Japan) in Japan, den Vereinigten Staaten, Großbritannien, Deutschland, Frankreich, Spanien, Russland, Australien, Neuseeland und/oder anderen Ländern.

Wir danken Ihnen für die Wahl dieses Icom-Produkts.
LESEN SIE ALLE ANWEISUNGEN sorgfältig und vollständig durch, bevor Sie dieses Produkt verwenden.

Sicherheitshinweise

⚠ **GEFAHR! NIEMALS** den Antennentuner ohne Erdung betreiben. Das Erdungskabel stets an die Erdungsklemme anschließen. Die Montageplatte **NICHT** als Erdungsklemme verwenden.

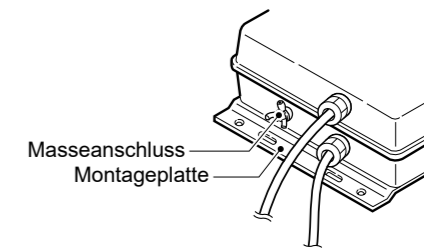

⚠ **GEFAHR! NIEMALS** ohne eine angeschlossene Antenne senden oder abstimmen. Wenn keine Antenne verwendet wird, führt das zu Schäden am Antennentuner.

⚠ **GEFAHR! HOCHSPANNUNG! NIEMALS** eine Antenne beim Senden oder Abstimmen berühren. Stellen Sie die Antenne so auf, dass Sie sicher sein können, dass sie nicht berührt wird.

⚠ **WARNUNG!** Befestigen Sie den AH-730 sicher mit den mitgelieferten Muttern und Schrauben. Sonst könnten Vibrationen und Stöße den Antennentuner lösen, so dass er herunterfällt und Verletzungen verursacht.

VORSICHT: NIEMALS das Steuerkabel und das Koaxialkabel verändern, verbiegen, verdrehen, daran ziehen oder es erhitzen.

VORSICHT: NIEMALS etwas Schweres an das Steuerkabel oder Koaxialkabel hängen.

VORSICHT: NIEMALS den AH-730 ohne Sicherung des Steuerkabels und Koaxialkabels montieren, so dass sie nicht herausgezogen oder gedehnt werden können.

VORSICHT: Montieren Sie den AH-730 horizontal oder vertikal mit dem Antennenanschluss nach oben.

VORSICHT: Den Antennentuner **NICHT** auf dem Kopf stehend montieren.

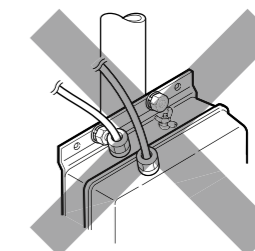

HINWEIS: Schließen Sie ein eigenes Koaxialkabel an den passenden Antennenanschluss an, wenn der Transceiver mehr als einen hat.

SCHÜTZEN Sie den Antennentuner vor starkem Regen und tauchen Sie ihn niemals in Wasser ein. Der Antennentuner entspricht den Anforderungen der Schutzart IPX4 bezüglich Spritzwasserschutz. Wenn der Antennentuner jedoch heruntergefallen ist, kann der Spritzwasserschutz nicht garantiert werden, weil der Antennentuner möglicherweise Risse bekommen hat oder die wasserdichte Abdichtung beschädigt wurde, o. Ä.

SINTONIZADOR DE ANTENA AUTOMÁTICO
AH-730

■ **Desecho**



El símbolo de reciclaje tachado en el producto, documentación o embalaje le recuerda que en la Unión Europea, todos los productos eléctricos y electrónicos, baterías y acumuladores (baterías recargables) deben llevarse a puntos de recogida concretos al final de su vida útil. No deseche estos productos con la basura doméstica no clasificada. Deséchelos de acuerdo con las normativas y leyes locales aplicables.

■ **Acerca De CE y la DDC**



Por el presente documento, Icom Inc. declara que las versiones del AH-730 que tienen el símbolo "CE" en el producto cumplen con los requisitos esenciales de la Directiva de Equipos de Radio 2014/53/UE y con la restricción del uso de ciertas sustancias peligrosas en los equipos eléctricos y electrónicos de la Directiva 2011/65/UE. El texto completo de la declaración de conformidad de la UE se encuentra disponible en la siguiente dirección de Internet: <https://www.icomjapan.com/support/>

■ **Definiciones explícitas**

TÉRMINO	DEFINICIÓN
⚠ ¡PELIGRO!	Puede producirse la muerte, lesiones graves o una explosión.
⚠ ¡ADVERTENCIA!	Existe el peligro de lesiones, incendios o descargas eléctricas.
PRECAUCIÓN	Pueden producirse daños en el equipo.
NOTA	Recomendado para uso óptimo. No existe riesgo de lesiones, incendios o descargas eléctricas.

Icom no se hace responsable de la destrucción, daños o rendimiento de cualquier equipo Icom o de terceros si su funcionamiento es incorrecto a causa de:

- Fuerza mayor, incluyendo, entre otros, incendios, terremotos, tormentas, inundaciones, relámpagos u otros desastres naturales, disturbios, revueltas, guerras o contaminación radioactiva.
- El uso de sintonizadores de antena de Icom con cualquier equipo que no haya sido fabricado o aprobado por Icom.

Icom, Icom Inc. y el logotipo de Icom, son marcas registradas de Icom Incorporated (Japón) en Japón, EE. UU., Reino Unido, Alemania, Francia, España, Rusia, Australia, Nueva Zelanda y/otros países.

Gracias por elegir este producto de Icom.
LEA TODAS LAS INSTRUCCIONES completa y detenidamente antes de utilizar este producto.

■ **Precauciones**

⚠ **¡PELIGRO! NUNCA** use el sintonizador de antena sin una conexión a tierra sólida. Conecte siempre el cable de toma a tierra al terminal de toma a tierra. **NO** use la placa de montaje como terminal de tierra.

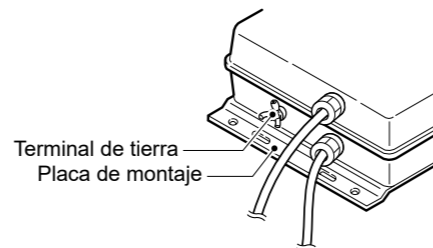

⚠ **¡PELIGRO! NUNCA** transmita o sintonice sin una antena conectada. No utilizar una antena dañará el sintonizador de antena.

⚠ **¡PELIGRO! ¡ALTA TENSION! NUNCA** toque la antena durante la transmisión o sintonización. Coloque la antena en una posición donde esté seguro de no tocarla.

⚠ **¡ADVERTENCIA!** Monte el AH-730 de forma segura con las tuercas y los pernos suministrados. De lo contrario, las vibraciones y los golpes pueden aflojar el sintonizador de antena, provocar su caída y causar lesiones personales.

PRECAUCIÓN: NUNCA modifique, doble, tuerza, tire o caliente el cable de control o el cable coaxial.

PRECAUCIÓN: NUNCA cuelgue algo pesado del cable de control o del cable coaxial.

PRECAUCIÓN: NUNCA monte el AH-730 sin asegurar el cable de control y el cable coaxial de modo que no puedan estirarse ni recibir tirones.

PRECAUCIÓN: Monte el AH-730 en una posición horizontal o vertical con el terminal de la antena hacia arriba.

PRECAUCIÓN: NO monte el sintonizador de antena al revés.

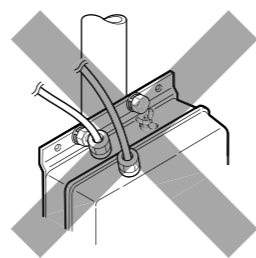

NOTA: Conecte un cable coaxial suministrado por el usuario al conector de antena adecuado si el transceptor tiene más de uno.

MANTENGA el sintonizador de antena alejado de lluvias intensas y nunca lo sumerja en agua. El sintonizador de antena cumple con los requisitos IPX4 de resistencia a las salpicaduras. Sin embargo, una vez el sintonizador de antena se haya caído, la protección contra salpicaduras no se podrá garantizar debido a que el sintonizador de antena podría presentar posibles daños tales como brechas, sello de estanqueidad dañado, etc.

SYNTONISEUR D'ANTENNE AUTOMATIQUE
AH-730

■ **Mise au rebut**



Le pictogramme poubelle barrée sur notre produit, notre documentation ou nos emballages vous rappelle qu'au sein de l'Union européenne, tous les produits électriques et électroniques, batteries et accumulateurs (batteries rechargeables) doivent être mise au rebut dans les centres de collecte indiqués à la fin de leur période de vie. Vous ne devez pas mettre au rebut ces produits avec les déchets municipaux non triés. Ils doivent être mis au rebut dans le respect de la réglementation en vigueur dans votre secteur.

■ **Informations CE et DOC**



Par la présente, Icom Inc. déclare que les versions de l'AH-730 qui ont le symbole « CE » sur le produit sont conformes aux exigences essentielles de la directive sur les équipements radio 2014/53/UE et à la limitation de l'utilisation de certaines substances dangereuses selon la directive sur les équipements électriques et électroniques 2011/65/UE. Le texte intégral de la déclaration de conformité UE est disponible à l'adresse internet suivante : <https://www.icomjapan.com/support/>

■ **Définitions explicites**

TERME	DÉFINITION
⚠ DANGER !	Risque d'accident mortel, de blessures corporelles graves ou d'explosion.
⚠ AVERTISSEMENT !	Risque de blessures corporelles, d'incendie ou de choc électrique.
MISE EN GARDE	Risque de dégât matériel.
REMARQUE	Recommandé pour une utilisation optimale. Aucun risque de blessures corporelles, d'incendie ou de choc électrique.

Icom n'est pas responsable de la destruction, de la détérioration ou des performances d'un équipement Icom ou non-Icom, si le dysfonctionnement survient à cause de :

- Force majeure, sans toutefois s'y limiter, les incendies, tremblements de terre, tempêtes, inondations, la foudre, ou autres catastrophes naturelles, perturbations, émeutes, guerre, ou contamination radioactive.
- L'utilisation des syntoniseurs d'antenne Icom avec tout équipement non fabriqué ou approuvé par Icom.

Le logo Icom, Icom Inc. et Icom sont des marques déposées de Icom Incorporated (Japon) au Japon, aux États-Unis, au Royaume-Uni, en Allemagne, en France, en Espagne, en Russie, en Australie, en Nouvelle-Zélande et/ou dans d'autres pays.

Merci d'avoir choisi ce produit Icom.
LISEZ TOUTES LES INSTRUCTIONS attentivement et entièrement avant d'utiliser ce produit.

■ **Précautions**

⚠ **DANGER ! NE JAMAIS** utiliser le syntonisateur d'antenne sans masse solide. Connecter toujours le fil de terre à la borne de terre. **NE PAS** utiliser la plaque de montage comme borne de terre.

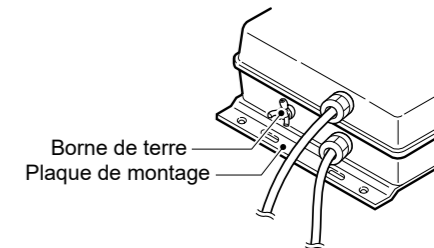

⚠ **DANGER ! NE JAMAIS** faire de transmission ou de syntonisation sans antenne connectée. Le fait de ne pas utiliser d'antenne a pour effet d'endommager le syntoniseur d'antenne.

⚠ **DANGER ! HAUTE TENSION ! NE JAMAIS** toucher l'antenne pendant la transmission ou la syntonisation. Placer l'antenne dans une position où il est certain qu'elle ne sera pas touchée.

⚠ **AVERTISSEMENT !** Monter solidement le AH-730 à l'aide des écrous et boulons fournis. Sinon, les vibrations et les chocs pourraient desserrer le syntoniseur d'antenne et le faire tomber, provoquant des blessures.

MISE EN GARDE : NE JAMAIS modifier, plier, tordre, tirer ou chauffer le câble de commande et le câble coaxial.

MISE EN GARDE : NE JAMAIS suspendre quelque chose de lourd sur le câble de commande et le câble coaxial.

MISE EN GARDE : NE JAMAIS monter le AH-730 sans fixer le câble de commande et le câble coaxial de façon à ce qu'ils ne puissent pas être tirés ou étirés.

MISE EN GARDE : Monter le AH-730 en position horizontale ou verticale avec la borne d'antenne en position relevée.

MISE EN GARDE : NE PAS monter le syntoniseur d'antenne à l'envers.

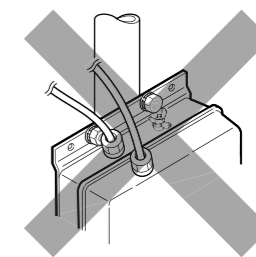

REMARQUE : Connecter un câble coaxial fourni par l'utilisateur au connecteur d'antenne approprié si l'émetteur-récepteur en possède plusieurs.

CONSERVER le syntoniseur d'antenne à l'abri des fortes pluies et ne jamais le plonger dans l'eau. Le syntonisateur d'antenne est conforme aux exigences IPX4 pour la résistance aux éclaboussures. Cependant, en cas de chute du syntoniseur d'antenne, la résistance aux éclaboussures ne peut plus être garantie, car le syntoniseur d'antenne risque d'être fissuré ou le joint d'étanchéité endommagé, etc.