



This adhesive base is only for radialless antenna with a total length of 1m or less and a mass of 200g or less. Diamond Antenna product SGM506R, SGM507, AZ510FX, AZ507R, etc. are recommended. Other antennas may be dropped and damaged while driving, so it is very dangerous and cannot be used.

1. It can be installed on vehicles that cannot be mounted on a common base such as the roof side and trunk lid.
2. The angle adjustment of the antenna can be done freely because it has a biaxial angle change mechanism.
3. It can be mounted not only on the car rooftop but also on the rear window glass.

#### • Before installation

Before attaching the double-sided tape, be sure to fit the base bracket exactly by bending it to the shape of the car body. When using tools such as pliers, protect the bracket with a cloth or cardboard to prevent damage to the base bracket.



## Cautions

1. If the shape of the base bracket and the vehicle body is not exact, mounting with double-sided tape will be incomplete and may cause the bracket to fall off.
2. The adhesive strength of double-sided tape that has been pasted and peeled will drop. Never use it as it may cause an accident.
3. When exposed to direct sunlight for a long time with the base attached, the color of the car body may differ from other area.

#### • Where to install



## Cautions

Do not attach the antenna to the windshield or driver side glass.

#### • Place not allowed to install

1. For models with a rear wiper, within the range of the rear wiper

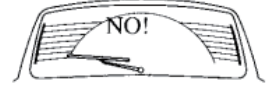

2. For models with a rear wiper, within the range of the rear wiper

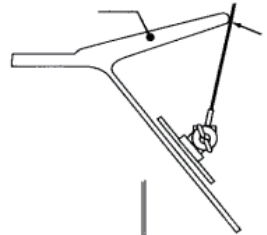

3. Where the glass surface is extremely curved

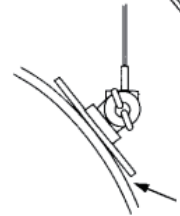

#### • Installation

Mount the HRK on a flat surface (rooftop, rear window, etc.). When pasting, clean the pasting surface in advance, wipe off moisture and oil, and dry it. If the temperature of the pasting surface is low in winter or cold areas, warm the pasting surface lightly with a dryer. Double-sided tape takes about 24 hours to achieve the prescribed adhesive strength. Do not operate with the antenna attached immediately after installation, as this is dangerous.



\* When mounting the base, be sure to use our genuine parts. When using genuine parts, be sure to completely remove the double-sided tape remaining on the base bracket. Installation with the remaining condition is dangerous because the strength is weakened.

The double-sided tape that comes with this product will not be peeled off when you use it. However, please keep in mind that it is easy to come off if a strong impact is applied to the installed antenna.

● **Caution during usage**

Remove the antenna for safety reasons when driving at extremely high speeds (100 km / h) or where the antenna hits a tree or branch. Also, for safety reasons, check the base bracket attachment state and screw looseness periodically.



● **How to remove the base**

When removing the adhesive base, put the octopus thread into the gap between the base bracket and the car body / window glass and rub it off to the left and right. The octopus thread will bite into your hand so use thick gloves. The remaining double-sided tape on the car body can be removed with a commercially available seal remover.

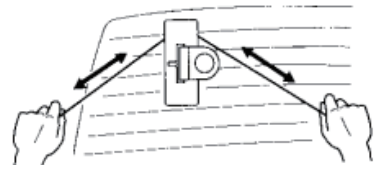

● **How to adjust angle**

Angle adjustment is performed with the center knob and side bolts. After adjusting, tighten the knob and bolt firmly.

● **Parts list**

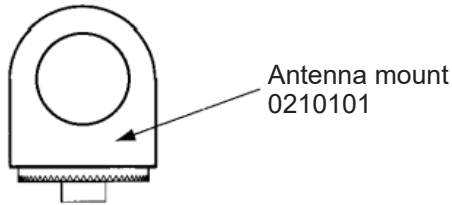
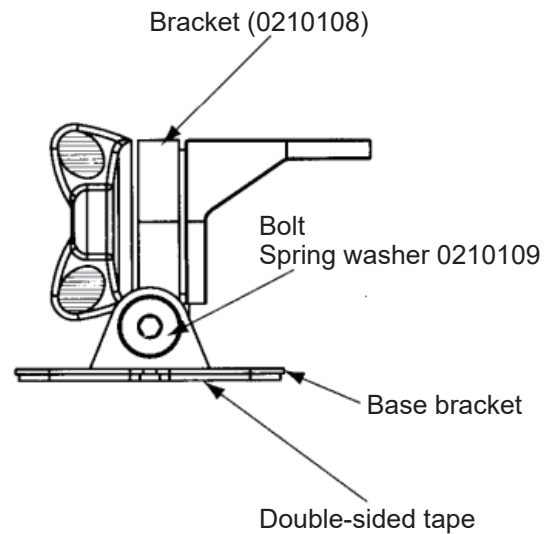
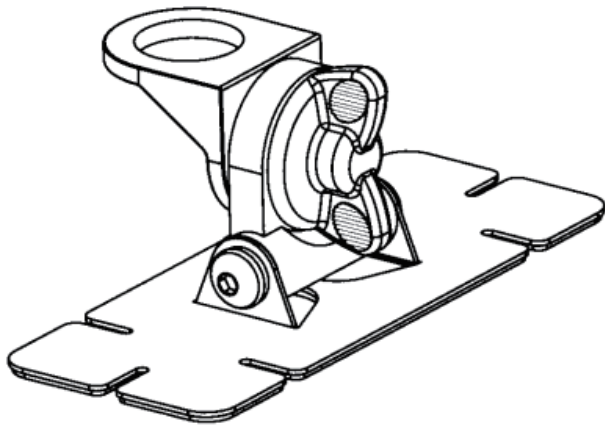

Antenna mount 0210101

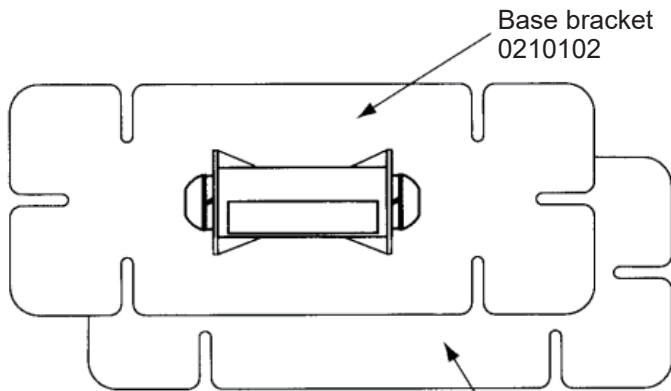

Base bracket 0210102

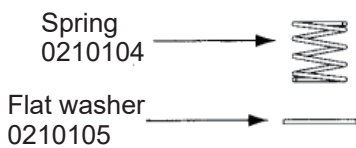

Spring 0210104

Flat washer 0210105

Double-sided tape 0210103

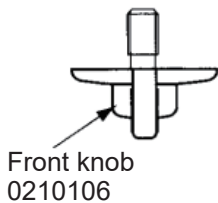

Front knob 0210106



Hexagonal wrench 0210107

- Though these products purchased are manufactured under strict quality control, if damage is caused by transporting, ask your dealer promptly.
- Design and specifications of these products will be changed for future improvement without advance notice.



**PASSION-RADIO.FR**  
Analogique - Numérique - SDR